

1:1

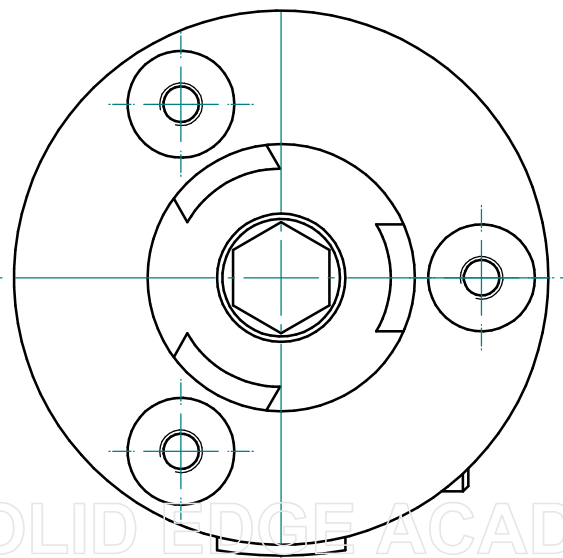

Cantidad	Denominación	Marca	Material
1	Casquillo separador	1*	
1	Horquilla	2*	
1	Soporte	3*	
2	Arandela plana M12 DIN125	4*	
1	Tornillo hexagonal M12 DIN 931	5*	
1	Tuerca almenada M12	6*	
2	Pasador aletas ϕ 3	7*	
1	Bulón	8*	
1	Rueda	9*	

	Nombre	Fecha	Solid Edge ST		
Dibujado	Angel	26/06/13	Siemens PLM Software		
Comprobado			Título		
Aprobado 1					
Aprobado 2					
Salvo indicación contraria cotas en milímetros ángulos en grados tolerancias $\pm 0,5$ y $\pm 1^\circ$			A3	Plano	Rev
			Archivo: Multzoa.dft		
			Escala	Peso	Hoja 1 de 1

SOLID EDGE ACADEMIC COPY