

N10/ ( N7/ N8/ )

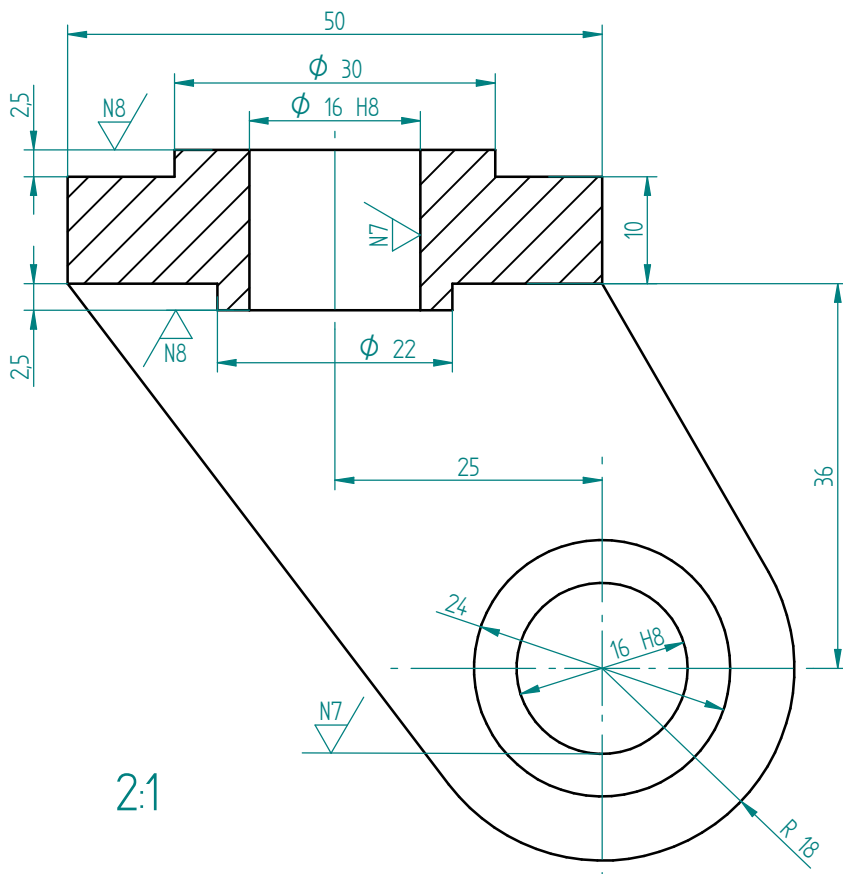

2:1

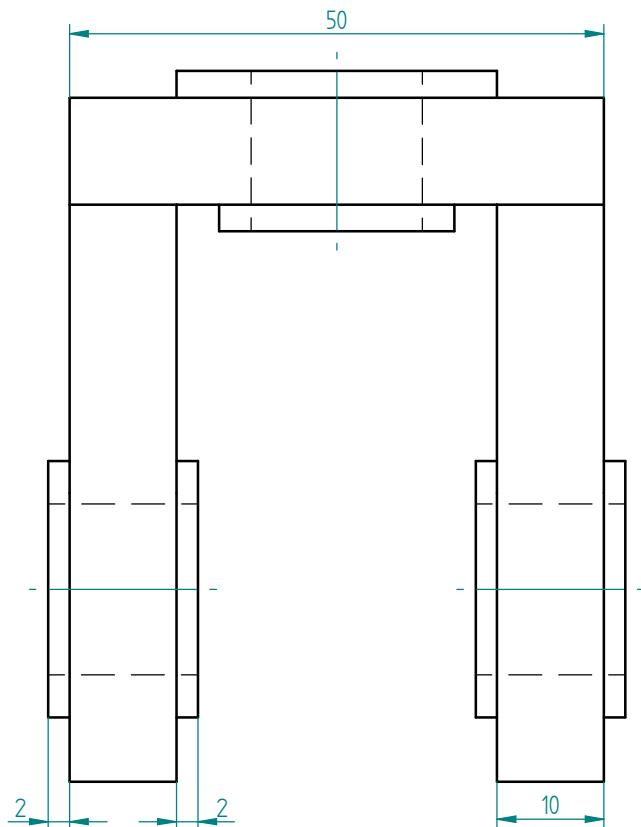
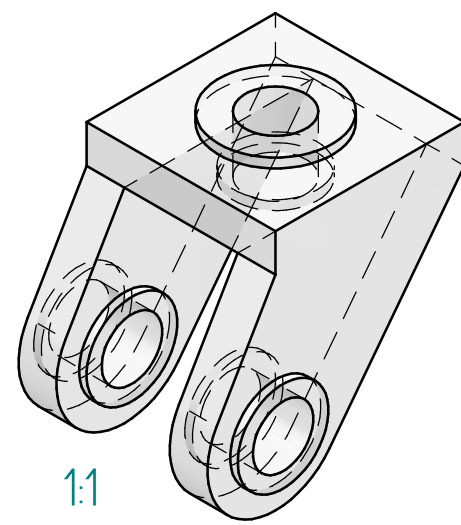

1:1

SOLID EDGE ACADEMIC COPY

	Nombre	Fecha	<b>Solid Edge ST</b> Siemens PLM Software	
Dibujado	Usuario	26/06/13		
Comprobado			Título	
Aprobado 1				
Aprobado 2			A3 Plano	
Salvo indicación contraria cotas en milímetros ángulos en grados tolerancias $\pm 0,5$ y $\pm 1^\circ$			Rev	
			Archivo: Horquilla.dft	
Escala		Peso	Hoja 1 de 1	